

HSG

让 世 界 爱 上 中 国 智 造

COMPANY INTRODUCTION

公司简介

佛山市宏石激光技术有限公司是一家致力于为全球用户提供激光智能装备解决方案的国家级高新技术企业，始终专注于激光智能装备制造领域，并秉持：高效、智能、环保、兼容的产品开发理念。

自 2006 年成立以来，宏山激光发展迅速，拥有四个标准化智能装备制造基地，总面积超 40000 平方米，在激光机器人、多轴联动专业切管、精密焊接智能自动生产线等领域实现柔性制造与数字化分级管理。宏山激光智能装备已在全球 100 多个国家与地区稳定运行，在精密器械、汽车配件、厨卫五金、电子电气、智能家居等行业拥有广泛的标杆客户范例。专业独立的核心研发团队和系统完善的售后技术支持部门，真正提供以客户为中心的服务型体验。

作为激光智能装备的领军企业，宏山激光一直专注于为工业 4.0 和未来工厂提供关键技术支持以及有针对性的个性化系统集成解决方案，帮助企业将智能制造落地实施，让智能制造改变工作，让智能制造变得触手可及。

HSG LASER is a national high-tech enterprise who is dedicated to providing laser intelligent equipment solutions to customers all over the world. We focus on the field of laser intelligent equipment manufacturing with the concept of efficient, intelligent, environmental and compatible product development.

Since our establishment in 2006, Beyond(HSG) Laser has developed rapidly with four standardized intelligent equipment manufacturing base covering an area more than 40,000 square meters. In the area of laser robot, multi-axis professional tube cutting, precise welding automated production lines and the related, we achieve Flexible Manufacturing and Digital Hierarchical Management. Beyond(HSG) Laser's intelligent equipment work stably in more than 100 countries and regions. And we have a wide range bench-marking paradigm in the area of precision appliance, auto parts, kitchen hardware, electronics, smart home industry. With professional, independent core R & D team and perfect systematic after-sales technical department, we truly provide customer-oriented service experience.

A leading enterprise of laser intelligent equipment, Beyond(HSG) Laser has been providing key technology and customized integration solutions for Industry 4.0 and future factories, helping enterprises to carry out intelligent manufacturing, making intelligent manufacturing to change our work within touch.





浙江分公司
ZHEJIANG BRANCH



山东分公司
SHANDONG BRANCH



苏州分公司
SUZHOU BRANCH



切管自动化事业部
PIPE-CUTTING AUTOMATION DIVISION



研发中心
R & D CENTER



高功率事业部
HIGH-POWER DIVISION



ISO9001 认证



ISO9001 CERTIFICATE

COMPANY HONOR

公司荣誉

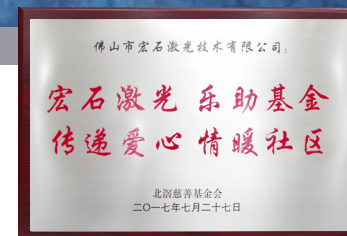
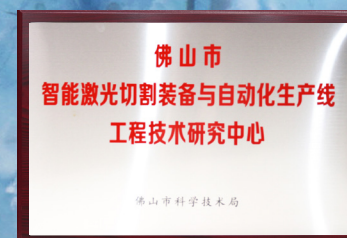
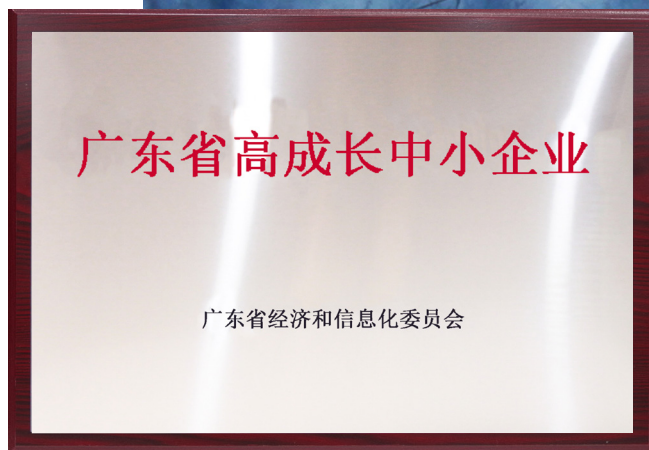



▲ 专利证书 / Patent Certificate

共 71 个专利，其中 47 个实用新型、8 个外观专利、16 个发明专利。

71 patents in total including 47 utility patents, 8 appearance patents and 16 innovation patents.

CORPORATE CULTURE

企业文化

使命 Mission

智造改变未来

Intelligent manufacturing changes the future.

愿景 vision

在 2038 年之前，成为全球领先的激光智能装备制造商

To become a world leading manufacture of laser intelligent equipment by 2038.

价值观 value

以客户为中心，以奋斗者为本，持续创新，实现公司价值与员工梦想

Focus on customers' needs, base on fighters' spirit.

persist in innovation, to achieve company value and staffs' dreams.

CONTENTS

目录

HS-G4020H HS-G4020S HS-G3015A	全包围激光切割机 09 FULLY ENCLOSED FIBER LASER CUTTING MACHINE
HS-G3015C HS-G3015B	敞开式激光切割机 17 OPEN TYPE FIBER LASER CUTTING MACHINE
HS-G6020E HS-G3015E	板管激光切割机 21 PLATE&TUBE LASER CUTTING MACHINE
HS-TH65 HS-TS65 HS-TP65	专业激光切管机 27 PROFESSIONAL TUBE LASER CUTTING MACHINE
HS-R30A HS-R20	三维激光切割机 37 THREE-DIMENSIONAL LASER CUTTING MACHINE
HS-R30A HS-R20	光纤激光焊接机 43 FIBER LASER WELDING MACHINE
	自动化生产线 49 AUTOMATED PRODUCTION LINE





FULLY ENCLOSED FIBER LASER CUTTING MACHINE

全包围激光切割机

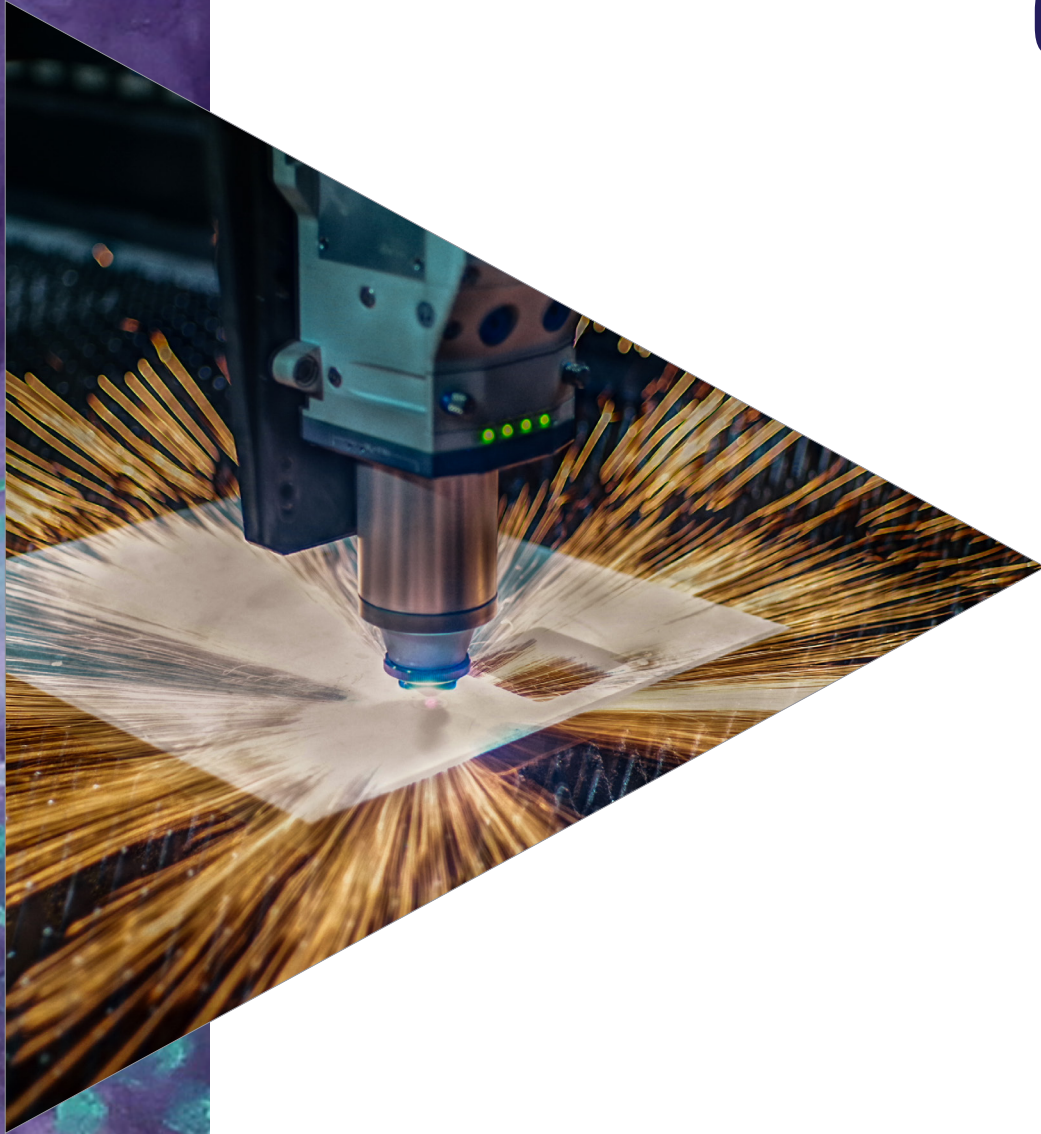

DOUBLE INTERCHANGEABLE TABLE
HIGHER EFFICIENCY

双工作台交换·效率更高

HS-G4020H

HS-G4020S

HS-G3015A

HS-G4020H

▶ NEW

▶ 万瓦高功率光纤激光切割机

HIGH-POWER FIBER LASER CUTTING MACHINE

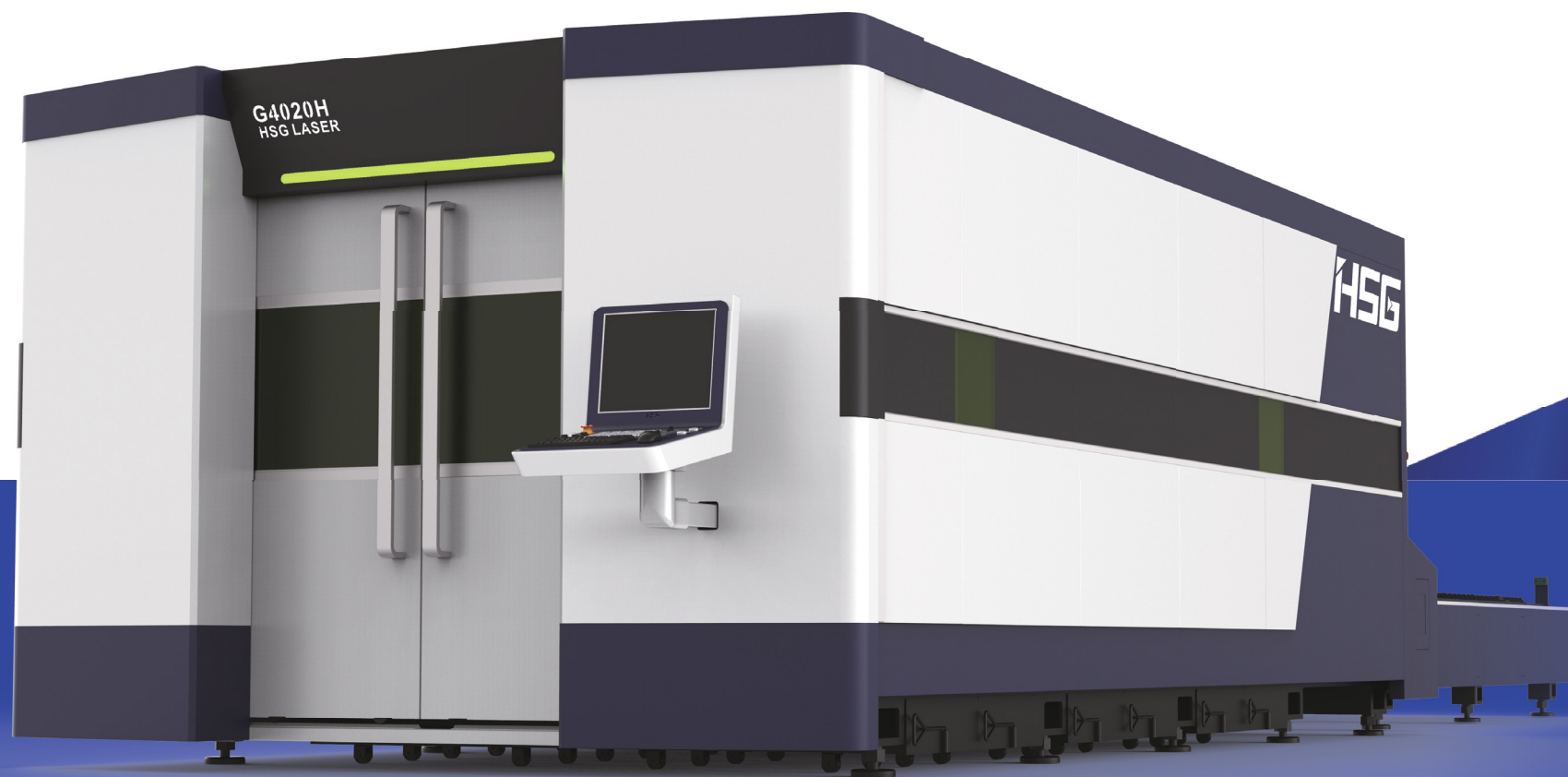

▲ 全包围式

▲ 万瓦高功率

▲ 激光切割

应用材料 / Applicable materials

专业用于切割 0.5-25mm 碳钢板, 0.5-20mm 不锈钢板, 0.5-16mm 铝, 0.5-12mm, 黄铜 0.5-8mm 紫铜, 镀锌板、电解板和硅钢等多种金属材料。(厚度以及材料与激光器有关)

Specially used for cutting 0.5-25mm carbon steel, 0.5-20mm stainless steel, 0.5-16mm aluminum, 0.5-12mm brass, 0.5-8mm copper, as well as galvanized steel, electrolytic steel and silicon steel etc (thickness and materials are related to fiber laser source power)

- ① 采用碳素结构钢拼板焊接, 错位蜂巢箱式结构, 避免焊接过程应力集中形变, 高温 600° 去应力退火工艺, 正常使用 20 年不变形;
- ② 横梁采用压力铸造航空铝结构, 铸造退火后进行粗加工, 再进行振动时效处理, 可以完全消除焊接及加工的应力, 密度高、重量轻、刚性好是设备高速运行的可靠保证。
- ③ 采用基于 PC 控制技术的理念和 Lightbus 系统、总线端子模块以及 TwinCAT 自动化软件的 Beckhoff 专用数控系统, 集成了很多激光切割控制专用功能模块, 功能强大, 人机界面好, 操作简单;
- ④ 专业全自动 SIGMANEST 套料软件, 是数控切割机实现“ 全时切割、高效切割和高套料率切割” 的核心技术, 是有效节省材料, 提高切割效率的根本保证。

Made of carbon structural steel plate welding, dislocation nest box construction to avoid welding stress deformation, 600°C high temperature release annealing stress with 20 years of normal use without distortion;

Gantry is casting aviation aluminum. It's done by annealing, roughing and aging treatment which release stress during welding and processing. High density, low weight and good rigidity is reliable guarantee for high speed running;

Adopting the idea of using the PC-based control technology and the Lightbus system the bus terminal module and TwinCAT automation software under Beckhoff CNC system. It's integrated many special laser cut control module, powerful, good interface, easy operation; sigmanest automatic programming expert edition nesting software, is core technology for CNC cutting machine to achieve "full time cutting, efficient cutting and high cutting rates". It's also guaranteed to save materials effectively and improve cutting efficiency.

性能指标参数 / Performance Index

加工幅面	Processing Area	4000X2000mm (可选择 optional)
激光器功率	Laser Power	6000W-15000W
最大运行速度	Max. Moving Speed	183m/min
最大加速度	Max. Acc. Speed	2.0G
定位精度	Positioning Accuracy	±0.03mm/m
重复定位精度	Reposition Accuracy	±0.03mm
整机重量	Whole Machine Weight	18000Kg
外观尺寸	Machine Dimensions	11500*3500*2500mm

HS-G4020S

▶ 高功率光纤激光切割机

HIGH-POWER FIBER LASER CUTTING MACHINE

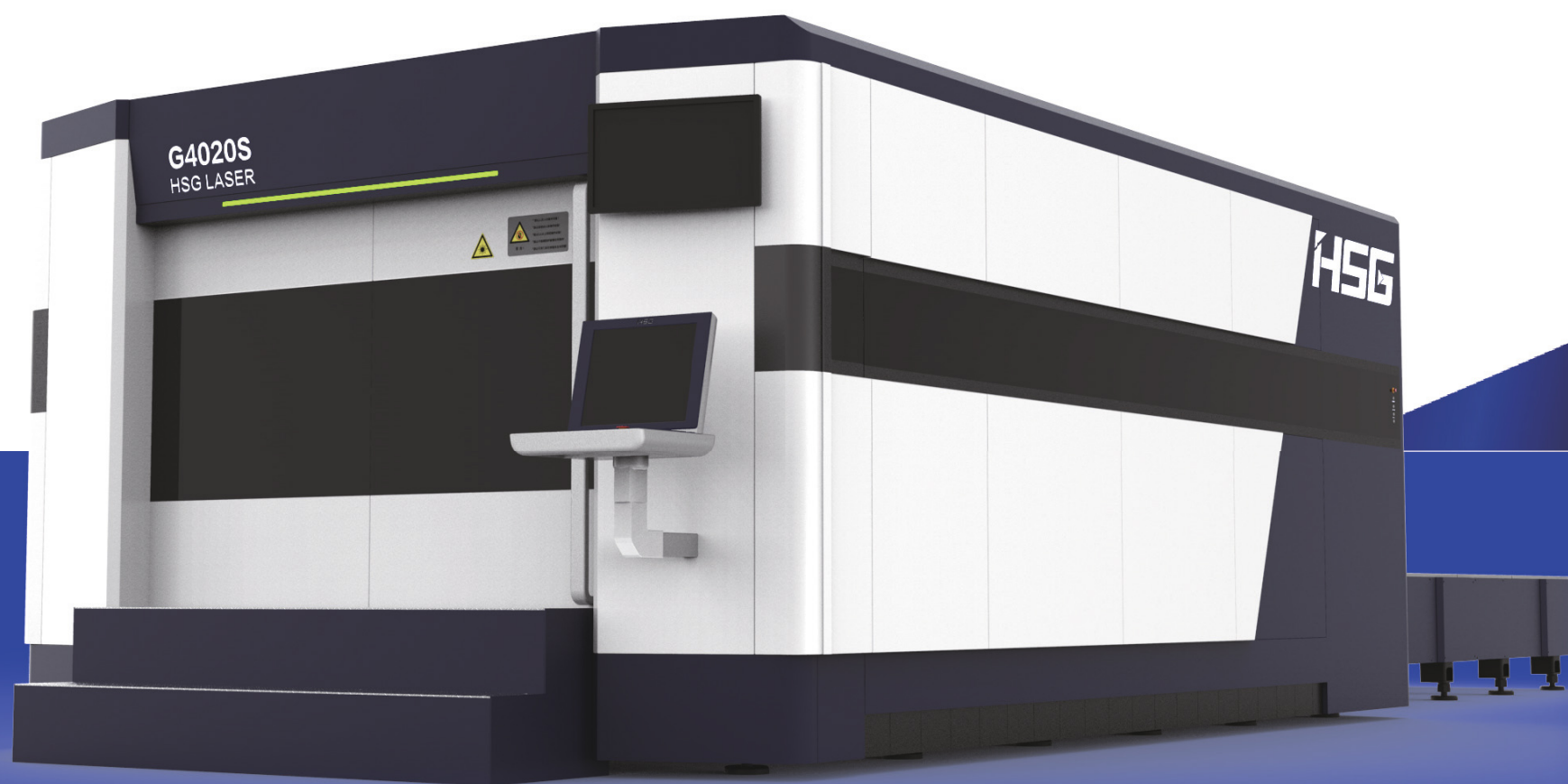

▲ 全包围式

▲ 高功率

▲ 激光切割

应用材料 / Applicable materials

专业用于切割 0.5-25mm 碳钢板, 0.5-20mm 不锈钢板, 0.5-16mm 铝, 0.5-12mm, 黄铜 0.5-8mm 紫铜, 镀锌板、电解板和硅钢等多种金属材料 (厚度以及材料与激光器有关)

Specially used for cutting 0.5-25mm carbon steel, 0.5-20mm stainless steel, 0.5-16mm aluminum, 0.5-12mm brass, 0.5-8mm copper, as well as galvanized steel, electrolytic steel and silicon steel etc (thickness and materials are related to fiber laser source power)

全进口高配置

BODY 床身

采用碳素结构钢拼板焊接, 错位蜂巢箱式结构, 避免焊接过程应力集中形变, 高温 600° 去应力退火工艺, 正常使用 20 年不变形;

BEAM 横梁

横梁采用压力铸造航空铝结构, 铸造退火后进行粗加工, 再进行振动时效处理, 可以完全消除焊接及加工的应力, 密度高、重量轻、刚性好是设备高速运行的可靠保证;

SYSTEM 倍福系统

采用基于 PC 控制技术的理念和 Lightbus 系统、总线端子模块以及 TwinCAT 自动化软件的 Beckhoff 专用数控系统, 集成了很多激光切割控制专用功能模块, 功能强大, 人机界面好, 操作简单;

NESTING 套料

SIGMANEST 套料软件, 是数控切割机实现“全时切割、高效切割和高套料率切割”的核心技术, 是有效节省材料, 提高切割效率的根本保证。

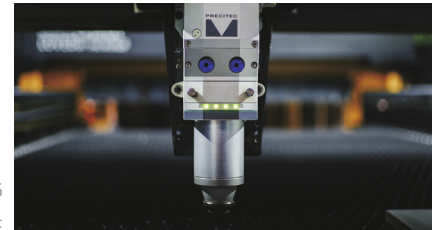
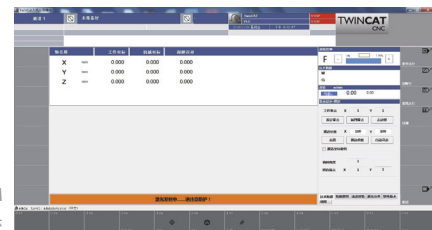
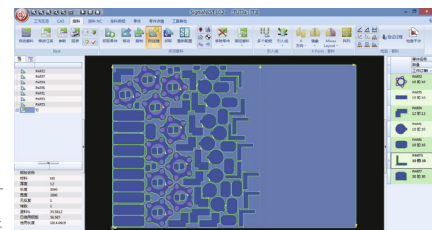
ALPHA
减速机HIGHYAG
激光头SYSTEM
倍福系统SIGMANEST
套料软件

性能指标参数 / Performance Index

加工幅面	Processing Area	4000X2000mm
激光器功率	Laser Power	4000W-8000W
最大运行速度	Max. Moving Speed	196m/min
最大加速度	Max. Acc. Speed	2.8G
定位精度	Positioning Accuracy	±0.03mm/m
重复定位精度	Reposition Accuracy	±0.03mm
整机重量	Whole Machine Weight	18000Kg
外观尺寸	Machine Dimensions	11500*3500*2500mm

HS-G3015A

▶ 高功率光纤激光切割机

HIGH-POWER FIBER LASER CUTTING MACHINE

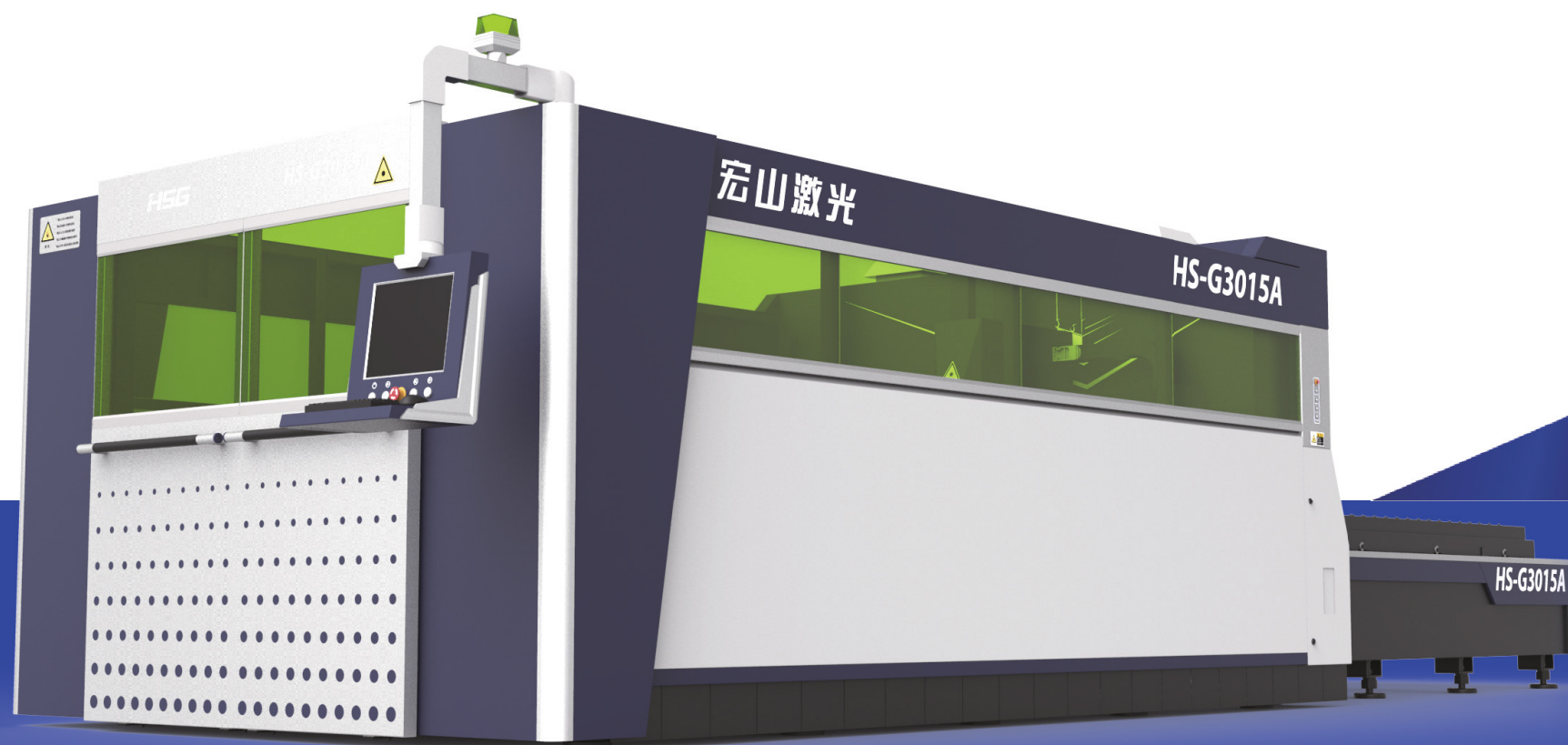

▲ 全包围式

▲ 高功率

▲ 激光切割

应用材料 / Applicable materials

专业用于切割 0.5-25mm 碳钢板, 0.5-20mm 不锈钢板, 0.5-16mm 铝, 0.5-12mm 黄铜, 0.5-8mm 紫铜, 镀锌板、电解板和硅钢等多种金属材料 (厚度以及材料与激光器有关)

Specially used for cutting 0.5-25mm carbon steel, 0.5-20mm stainless steel, 0.5-16mm aluminum, 0.5-12mm brass, 0.5-8mm copper, as well as galvanized steel, electrolytic steel and silicon steel etc (thickness and materials are related to fiber laser source power)

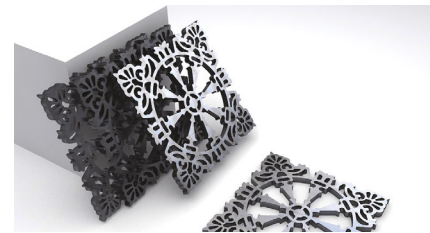

性能指标参数 / Performance Index

加工幅面	Processing Area	3000X1500mm
激光器功率	Laser Power	500W-3000W
最大运行速度	Max. Moving Speed	140m/min
最大加速度	Max. Acc. Speed	1.2G
定位精度	Positioning Accuracy	±0.05mm/m
重复定位精度	Reposition Accuracy	±0.05mm
整机重量	Whole Machine Weight	7500Kg
外观尺寸	Machine Dimensions	8500*2900*1900mm

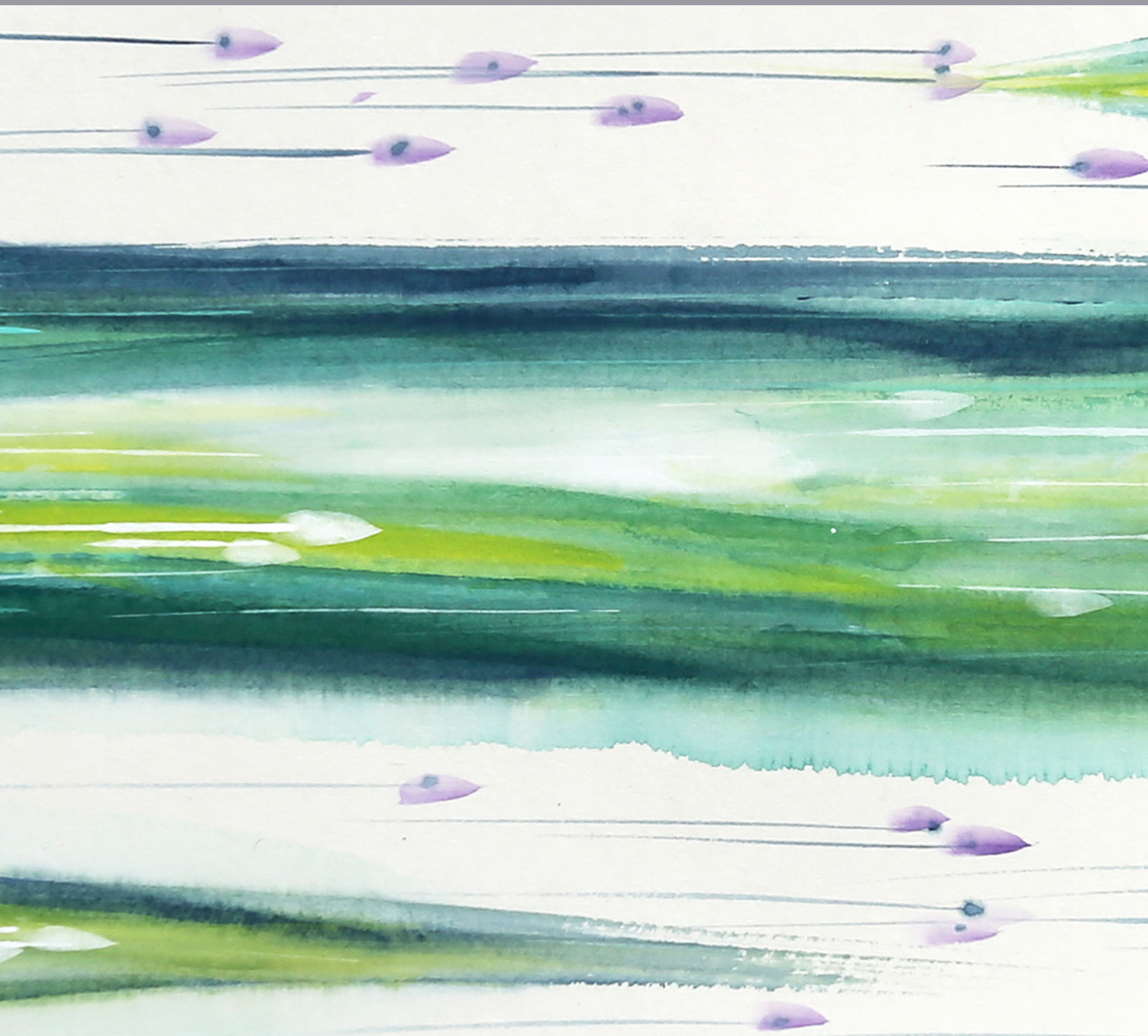

OPEN TYPE FIBER LASER CUTTING MACHINE

敞开式激光切割机

FAST SPEED · HIGH PRECISION

速度快 · 精度高

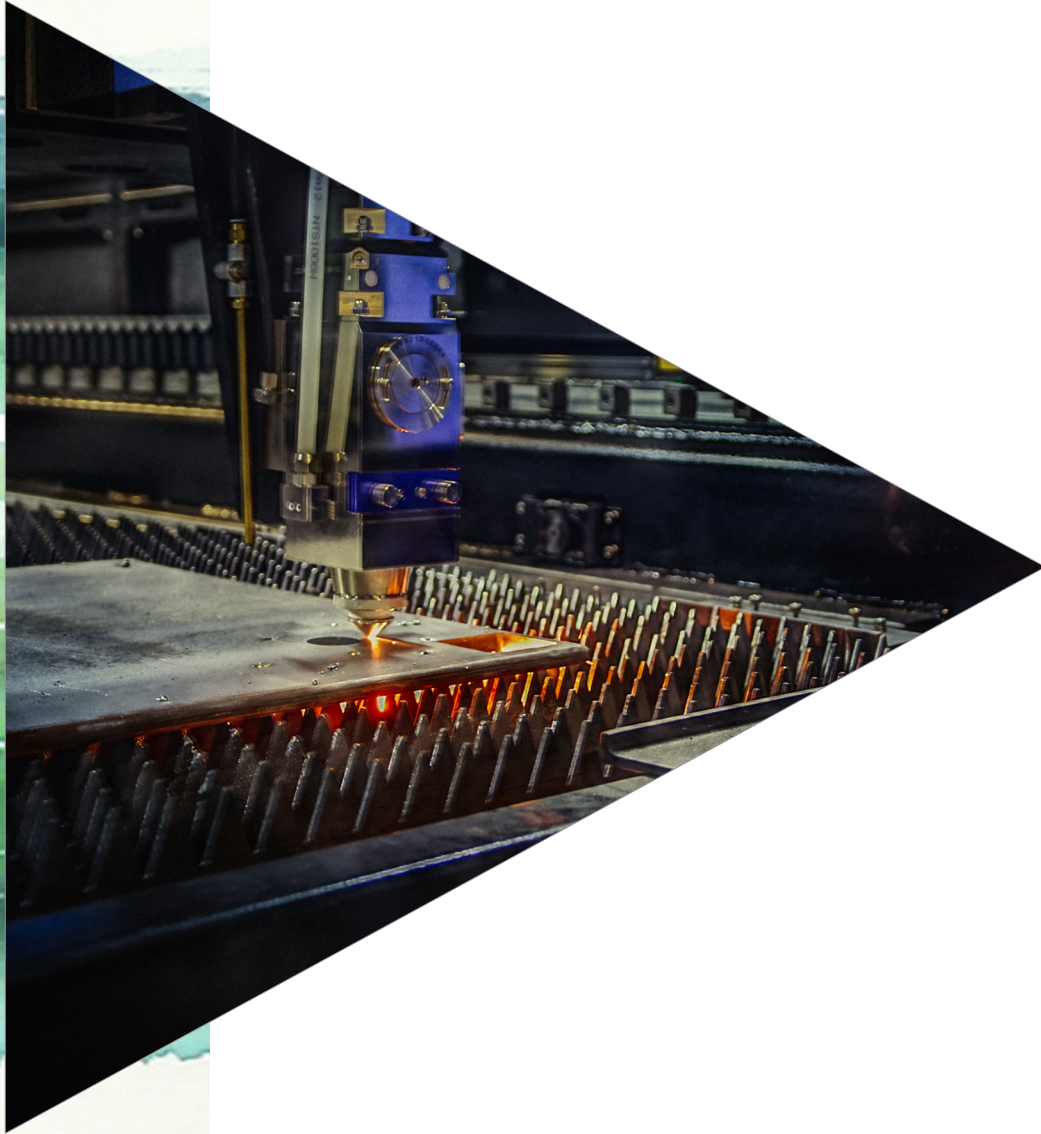

HS-G3015B

HS-G3015C

HS-G3015C

▶ 敞开式光纤激光切割机

OPEN TYPE FIBER LASER CUTTING MACHINE



采用日本原装进口伺服电机，全套全球品牌第一的德国阿尔法齿轮齿条、减速机，保用6年，最快100m/min，加速度1.0G。

Adopt Japan originally imported servo motor, the NO.1 ALPHA rack&pinion and speed reducer in the world, guarantee usage for 6 years, max. moving speed reaches 100m/min, acceleration speed 1.0G.

性能指标参数 / Performance Index

加工幅面	Processing Area	3000X1500mm
激光器功率	Laser Power	500W-2000W
最大运行速度	Max. Moving Speed	100m/min
最大加速度	Max. Acc. Speed	1.0G
定位精度	Positioning Accuracy	±0.05mm/m
重复定位精度	Reposition Accuracy	±0.05mm
整机重量	Whole Machine Weight	3300Kg
外观尺寸	Machine Dimensions	4600*2600*1650mm

▲ 敞开式

▲ 速度快

▲ 激光切割

在加工效率方面及切割速度达到国内领先，加速度达到 0.5G，运行速度最大达到 60m/min。切割精度：在切割管材时运动精度上保证在 $\pm 0.1\text{mm}$ 。定位精度 0.05mm/m，重复定位精度达到 $\pm 0.05\text{mm}$ 。

It has reached national leading level in regards of cutting efficiency and cutting speeds, acceleration speed up to 0.5G and moving speed up to 60m/min. Cutting precision: kinematic precision on tubes assures to be within $\pm 0.1\text{mm}$. kinematic precision for metal sheet is $\pm 0.05\text{mm}$, positioning precision up to $\pm 0.05\text{mm/m}$ and repeated positioning precision up to $\pm 0.05\text{mm}$.

HS-G3015B

板管一体光纤激光切割机

SHEET AND TUBE FIBER LASER CUTTING MACHINE

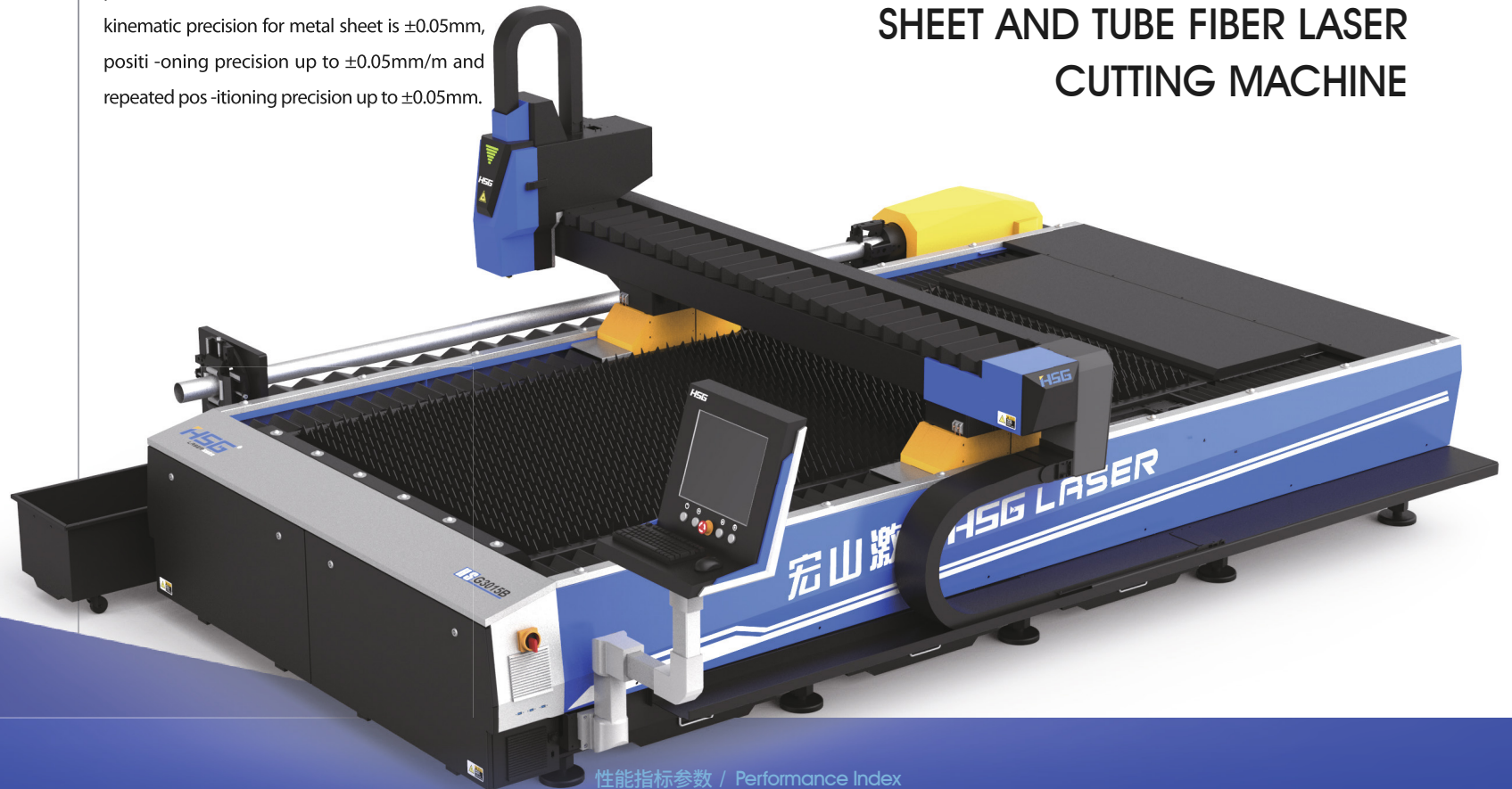

性能指标参数 / Performance Index

加工幅面	Processing Area	3000X1500mm
激光器功率	Laser Power	500W-2000W
最大运行速度	Max. Moving Speed	60m/min
最大加速度	Max. Acc. Speed	0.5G
定位精度	Positioning Accuracy	$\pm 0.05\text{mm/m}$
重复定位精度	Reposition Accuracy	$\pm 0.05\text{mm}$
整机重量	Whole Machine Weight	4800Kg
外观尺寸	Machine Dimensions	4950*3150*1650mm

▲ 敞开式

▲ 板管一体

▲ 激光切割

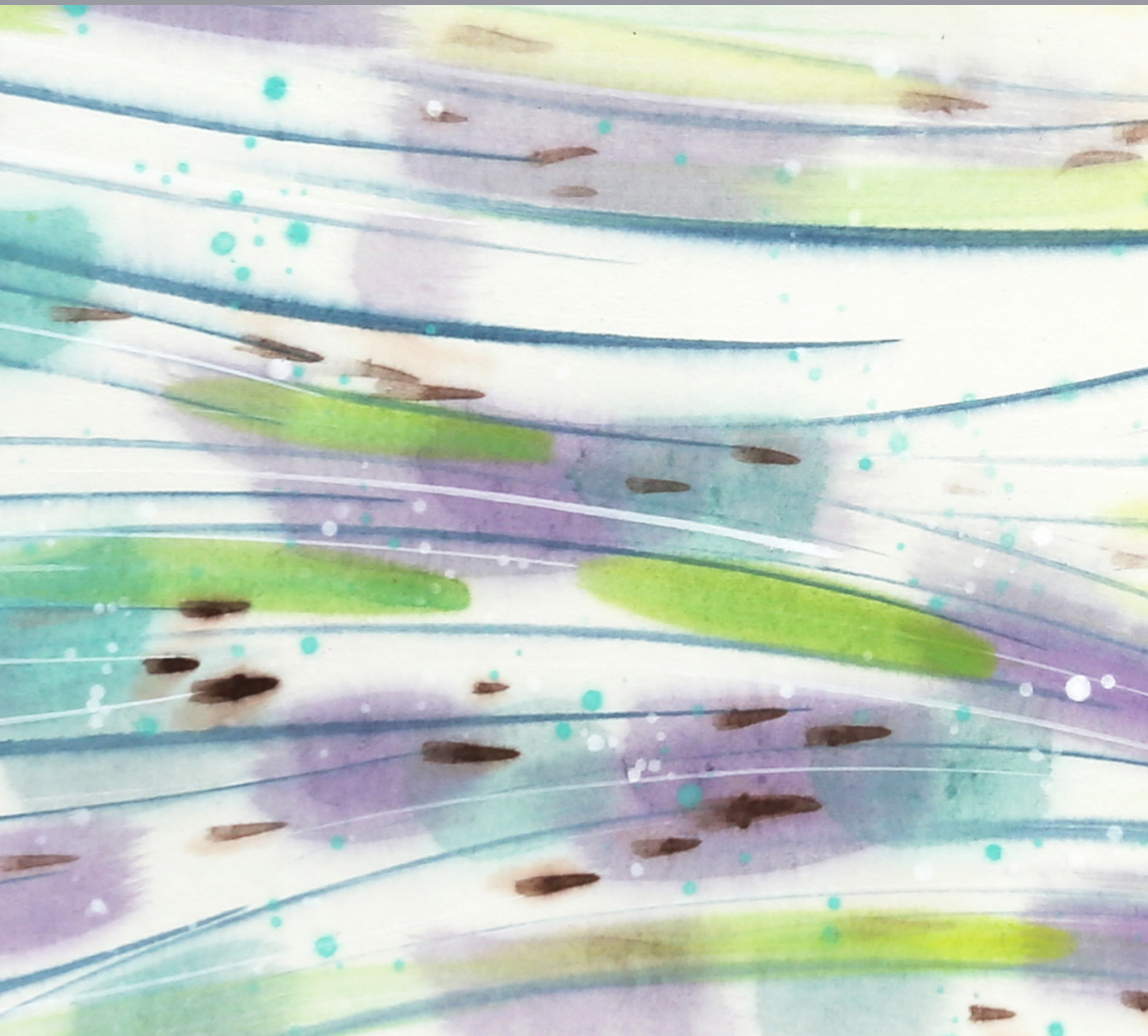

TUBE AND SHEET FIBER LASER CUTTING MACHINE

板管激光切割机

DUAL USE FOR TUBE AND SHEET
CUTTING EXPERT

板管两用·切割专家

HS-G3015E

HS-G6020E

HS-G3015E-60T

▶ 6米双驱交换台带防护板管一体机

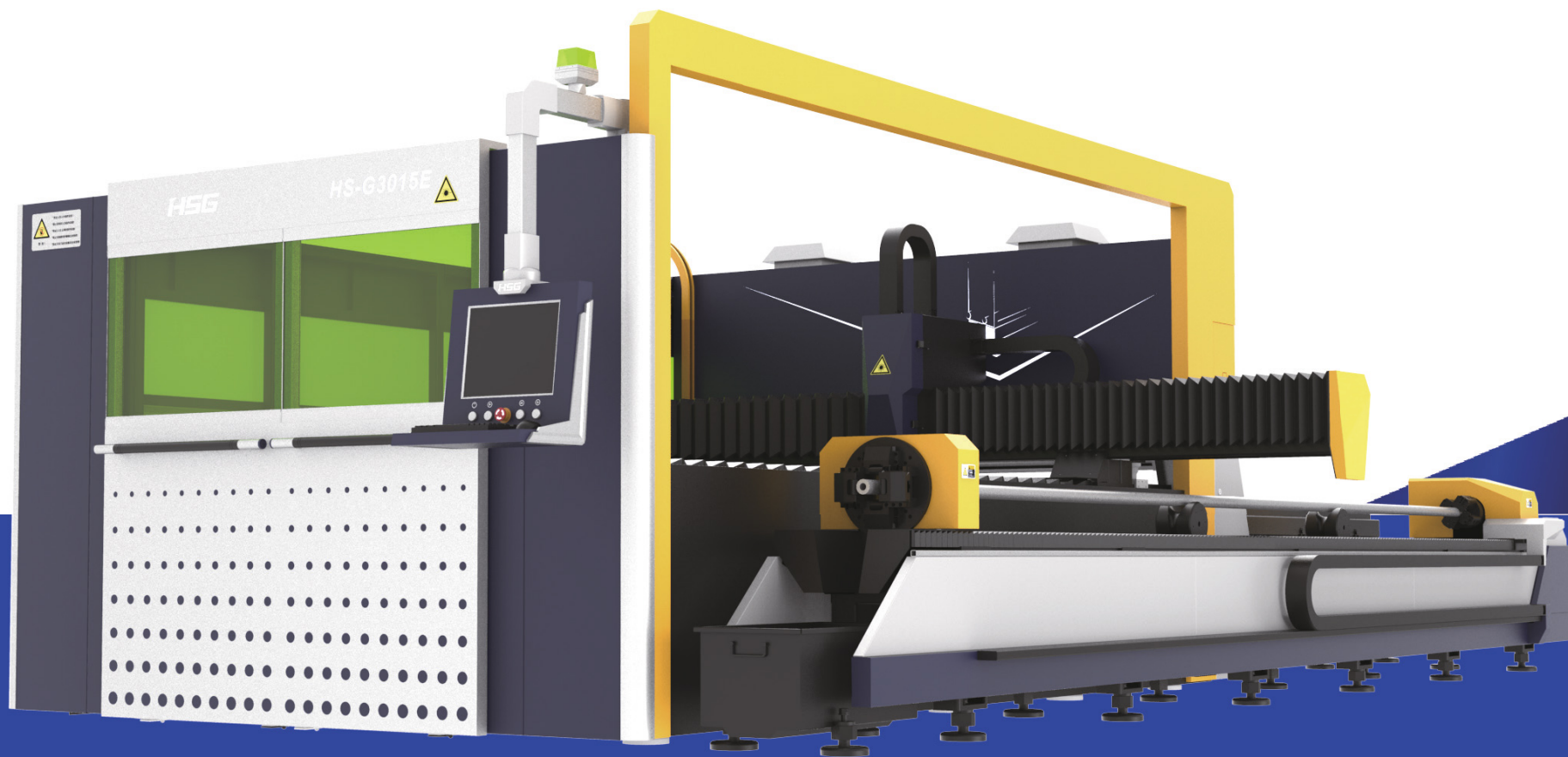

▲ 6米双驱

▲ 板管一体

▲ 激光切割

应用材料 / Applicable materials

管材

专业切割方管、圆管、矩形管、D型管和六边形管等各类型管材，方管口 20*20-100*100mm 圆管 Φ 20- Φ 150mm，管壁厚度 0.5-5mm 碳钢管，0.5-5mm 不锈钢管。

板材

专业切割 0.5-16mm 碳钢板，0.5-8mm 不锈钢板，0.5-6mm 黄铜，0.5-4mm 紫铜及镀锌板、电解板和硅钢等多种金属材料（厚度以及材料与激光器有关）

TUBES

Specially used for cutting square tubes, round tubes, rectangle tubes, D-shaped tubes and hexagon tubes etc. Cutting capacity- square tubes: 20*20-100*100mm, round tubes: 20-150mm, thickness 0.5-5mm carbon steel tubes, 0.5-5mm stainless steel tubes.

SHEETS

Specially used for cutting 0.5-16mm carbon steel, 0.5-8mm stainless steel, 0.5-6mm brass, 0.5-4mm copper, as well as galvanized steel, electrolytic steel and silicon steel etc. (thickness and materials are related to fiber laser source power)

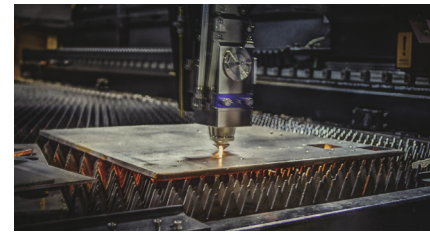

性能指标参数 / Performance Index

加工幅面	Processing Area	3000X1500mm (可选择 optional)
激光器功率	Laser Power	500W-4000W
最大运行速度	Max. Moving Speed	60m/min
最大加速度	Max. Acc. Speed	0.5G
定位精度	Positioning Accuracy	\pm 0.05mm/m
重复定位精度	Reposition Accuracy	\pm 0.05mm
整机重量	Whole Machine Weight	9500Kg
外观尺寸	Machine Dimensions	9000*3650*2100mm

HS-G6020E

▶ NEW

▶ 6米双驱交换台带防护板管一体机

DUAL-DRIVE 6M TUBES AND SHEETS FIBER LASER CUTTING MACHINE WITH ENCLOSURE AND INTERCHANGEABLE TABLE



▲ 6米双驱

▲ 板管一体

▲ 激光切割

在切管行业主要解决了对于切割各种类型的管材如方管、圆管、椭圆管、D型管、多边形管、腰形管都有着高精度、高效率的表现，切管长度可达6米；

This machine has provided cutting solutions for various shapes of tubes, such as square tubes, round tubes, oval tubes, D-shape tubes, polygonal tubes, waist type tubes and delivers efficient cutting performance. It can cut up to 6-meter long tubes;

数控系统上使用国内领先的上海柏楚切管系统，全新的人机交互界面，切割模拟CAM软件实时跟踪显示。针对切管行业的工艺参数库，以及无线手持盒的使用，达到国内领先水平；

The control system is National leading Shanghai Cyptube system. Equipped with new Human Machine Interaction, cutting simulates CAM software real-time tracking display. Together with the cutting parameters database of tubes cutting industry and application of wireless control box, this machine reaches leading level in China;

G6020E-22Q

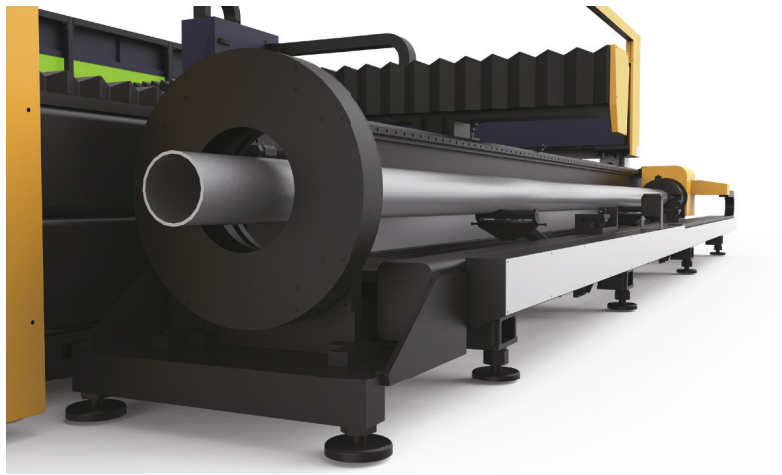

G6020E-35Q

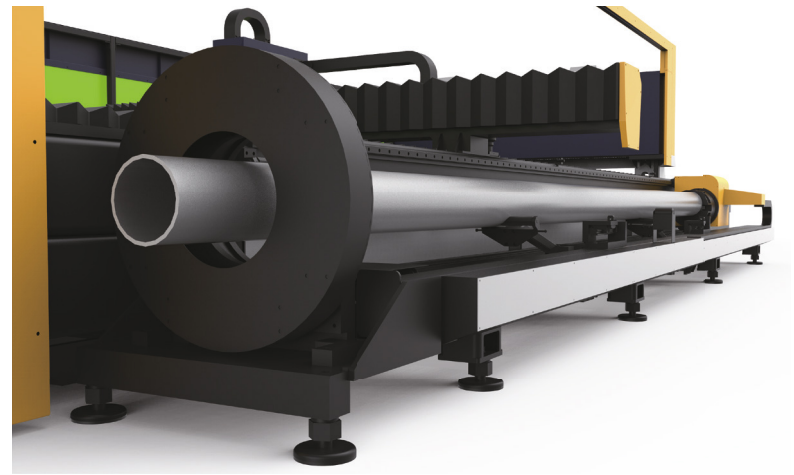

管型	Pipe Tube	规格范围 Cutting Ability (mm)
正圆管	Round Tube	$\phi 20-\phi 210$
正方管	Square Tube	$\square 20*20-\square 150*150$
矩形管	Rectangle Tube	\square 各边长 : 20-150
椭圆管	Oval Tube	$\ominus 20-150$
腰型管	Waist-Shape Tube	$\text{⊏} 20-150$
六边形管	Hexagon Tube	$\hexagon \square 20*20-\square 150*150$

管型	Pipe Tube	规格范围 Cutting Ability (mm)
正圆管	Round Tube	$\phi 20-\phi 325$
正方管	Square Tube	$\square 20*20-\square 230*230$
矩形管	Rectangle Tube	\square 各边长 : 20-230
椭圆管	Oval Tube	$\ominus 20-230$
腰型管	Waist-Shape Tube	$\text{⊏} 20-230$
六边形管	Hexagon Tube	$\hexagon \square 20*20-\square 230*230$

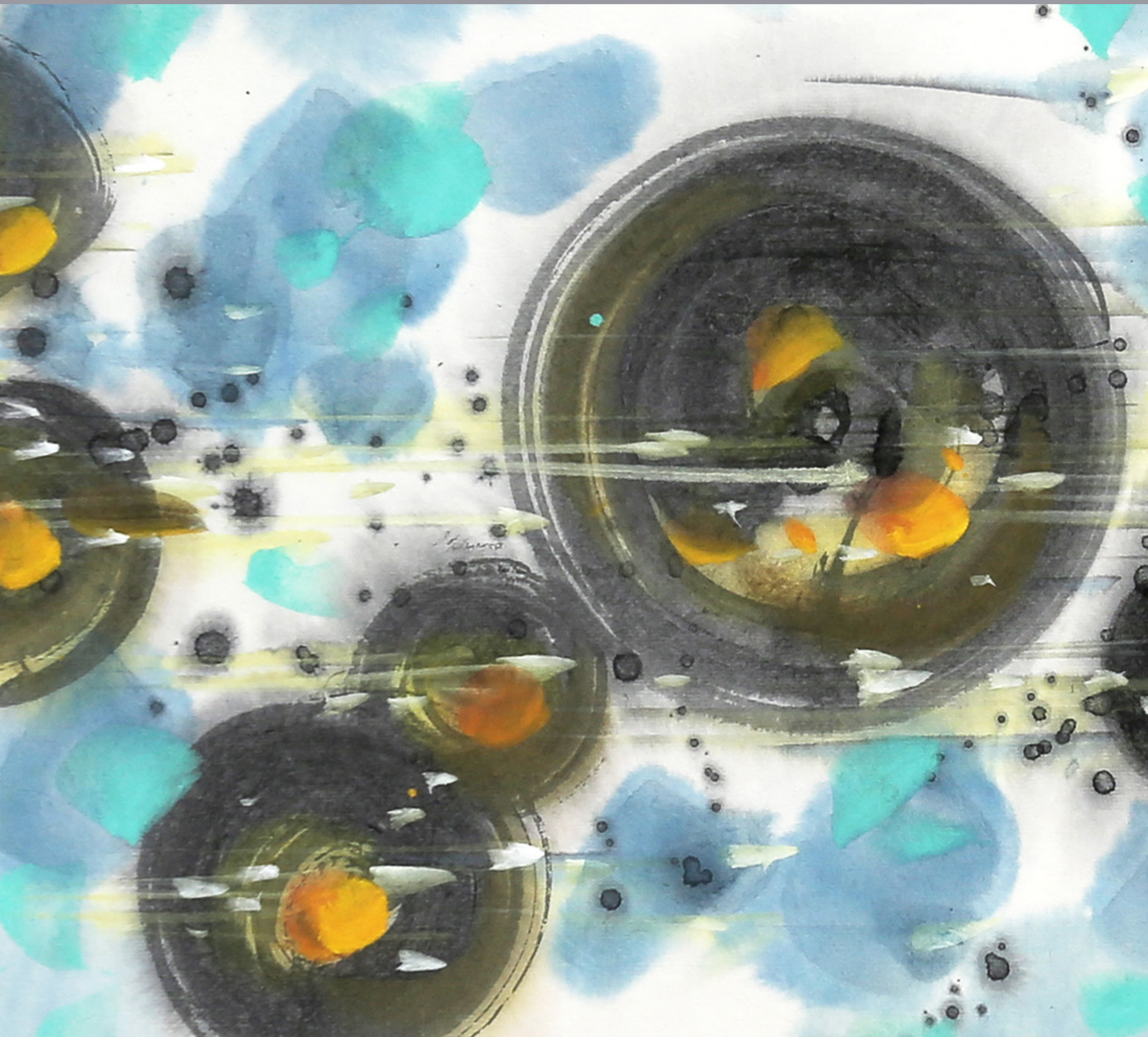

PROFESSIONAL TUBE LASER CUTTING MACHINE

专业激光切管机

CARE ABOUT SCIENCE&TECHNOLOGY
CREATE LEGEND
注重科技·创造传奇

HS-TH65

HS-TS65

HS-TP65

HS-E22

HS-TH65

▶ 专业激光切管机

PROFESSIONAL PIPE LASER CUTTING MACHINE

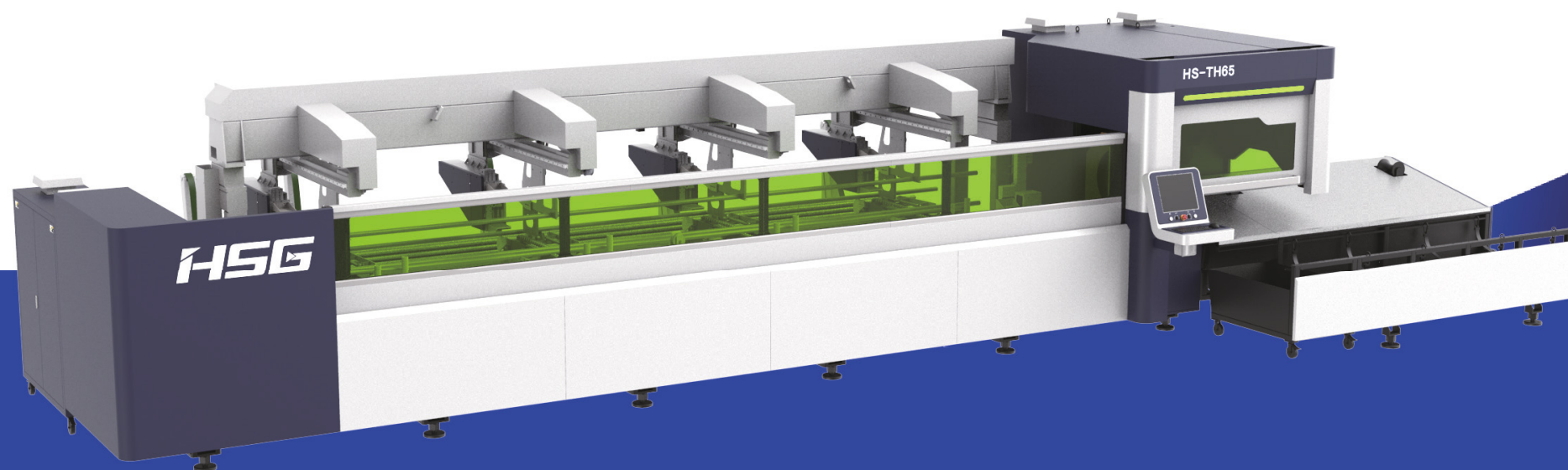

▲ 专业切管

▲ 激光切割

应用材料 / Applicable materials

管材

专业切割方管、圆管、矩形管、D型管和六边形管等各类型管材，方管口 20*20-150*150mm，圆管 Φ 20- Φ 210mm，管壁厚度 0.5-10mm 碳钢管，0.5-10mm 不锈钢管。（厚度以及材料与激光器有关）

TUBES

Professionally cutting square tubes, round tubes, rectangle tubes, D-shap tubes and hexagon tubes etc. Cutting capacity- square tubes: 20*20-150*150mm, round tubes: 20-210mm, thickness 0.5-5mm carbon steel tubes, 0.5-5mm stainless steel tubes.

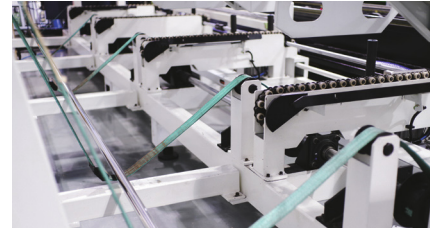
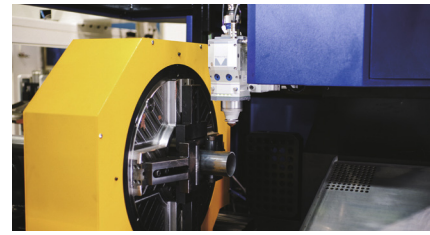

性能指标参数 / Performance Index

激光波长	Laser Wavelength	1070-1080mm
激光器功率	Laser Power	1000W-4000W
最大运行速度	Max. Moving Speed	100m/min
最大加速度	Max. Acc. Speed	1.0G
定位精度	Positioning Accuracy	\pm 0.03mm/m
重复定位精度	Reposition Accuracy	\pm 0.03mm
整机重量	Whole Machine Weight	10000Kg
外观尺寸	Machine Dimensions	12000*3500*2800mm

HS-TS65

▶ NEW

▶ 全自动激光切管机

AUTOMATIC TUBE LASER CUTTING MACHINE



▲ 全自动

▲ 专业切管

▲ 激光切割

应用材料 / Applicable materials

管材

专业切割方管、圆管、矩形管、D型管和六边形管等各类型管材，方管口 12*12-200*200mm，圆管 Φ 12- Φ 254mm，管壁厚度 0.5-10mm 碳钢管，0.5-10mm 不锈钢管。（厚度以及材料与激光器有关）

TUBES

Professionally cutting square tube, round tubes, rectangle tubes, D-shaped tubes and hexagon tubes etc. Cutting capacity- square tubes: 12*12-200*200mm, round tubes: 12-254mm, thickness 0.5-5mm carbon steel tubes, 0.5-5mm stainless steel tubes. (Cutting thickness and material is related to laser source)

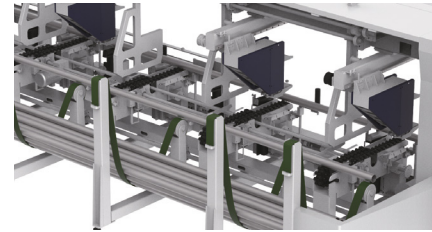

性能指标参数 / Performance Index

激光波长	Laser Wavelength	1070-1080mm
激光器功率	Laser Power	1000W-4000W
最大运行速度	Max. Moving Speed	120m/min
最大加速度	Max. Acc. Speed	1.2G
定位精度	Positioning Accuracy	\pm 0.03mm/m
重复定位精度	Reposition Accuracy	\pm 0.03mm
整机重量	Whole Machine Weight	12000Kg
外观尺寸	Machine Dimensions	12000*3500*2800mm

HS-TP65

▶ 五轴联动激光切管机

5-AXIS TUBE LASER CUTTING MACHINE

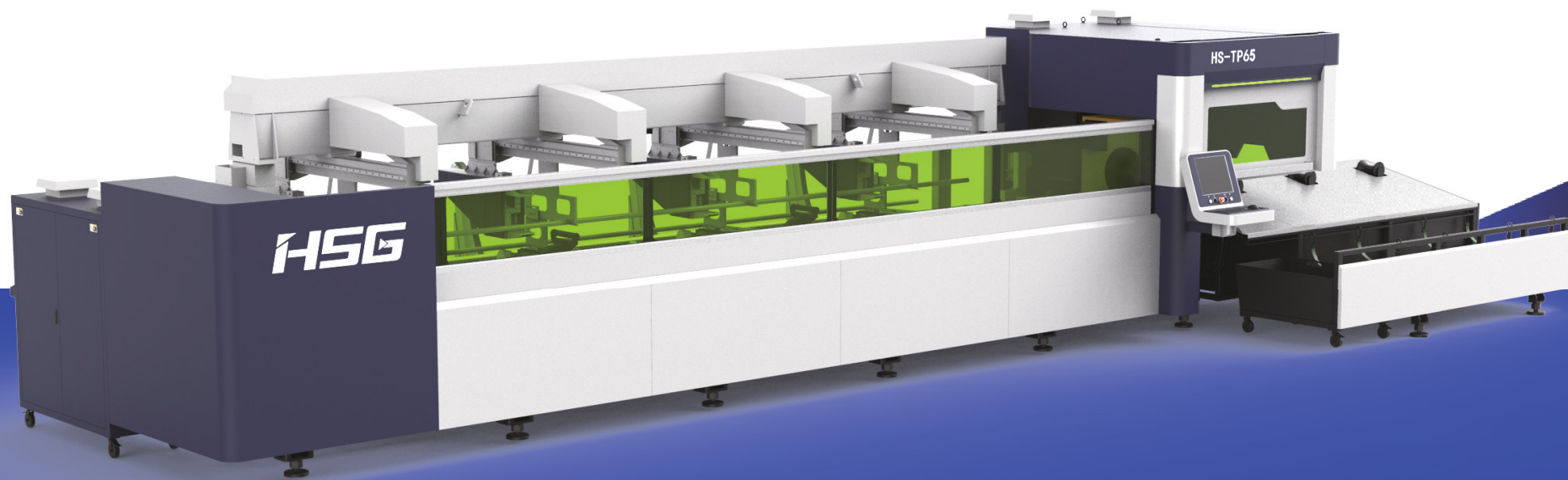

▲ 3D 切割头

▲ 五轴联动

▲ 激光切管

应用材料 / Applicable materials

管材

专业切割方管、圆管、矩形管、D型管和六边形管等各类型管材，方管口 20*20-150*150mm，圆管 Φ 20- Φ 210mm，管壁厚度 0.5-10mm 碳钢管，0.5-10mm 不锈钢管。（厚度以及材料与激光器有关）

TUBES

Professionally cutting square tubes, round tubes, rectangle tubes, D-shap tubes and hexagon tubes etc. Cutting capacity- square tubes: 20*20-150*150mm, round tubes: 20-210mm, thickness 0.5-5mm carbon steel tubes, 0.5-5mm stainless steel tubes. (Cutting thickness and material is related to laser source)

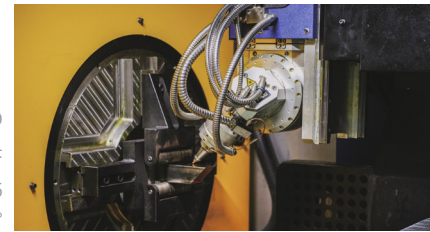
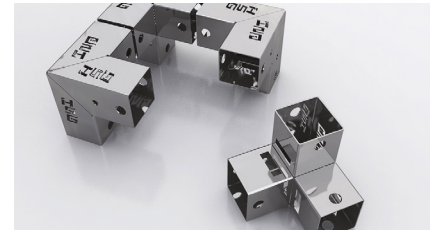

3D 5-AXIS CUTTING HEAD
三维五轴切割头

GERMANY IMPORTED WITH MAX. SWING AXIS ANGLE +/-135°
采用全进口德国工艺制造 摆角轴最大角度 ±135°

性能指标参数 / Performance Index

激光波长	Laser Wavelength	1070-1080mm
激光器功率	Laser Power	1000W-4000W
最大运行速度	Max. Moving Speed	100m/min
最大加速度	Max. Acc. Speed	1.0G
定位精度	Positioning Accuracy	±0.03mm/m
重复定位精度	Reposition Accuracy	±0.03mm
整机重量	Whole Machine Weight	10000Kg
外观尺寸	Machine Dimensions	12000*3500*2800mm

HS-E22

▶ NEW

▶ 全自动激光切管机

TUBE CUTTING MACHINE

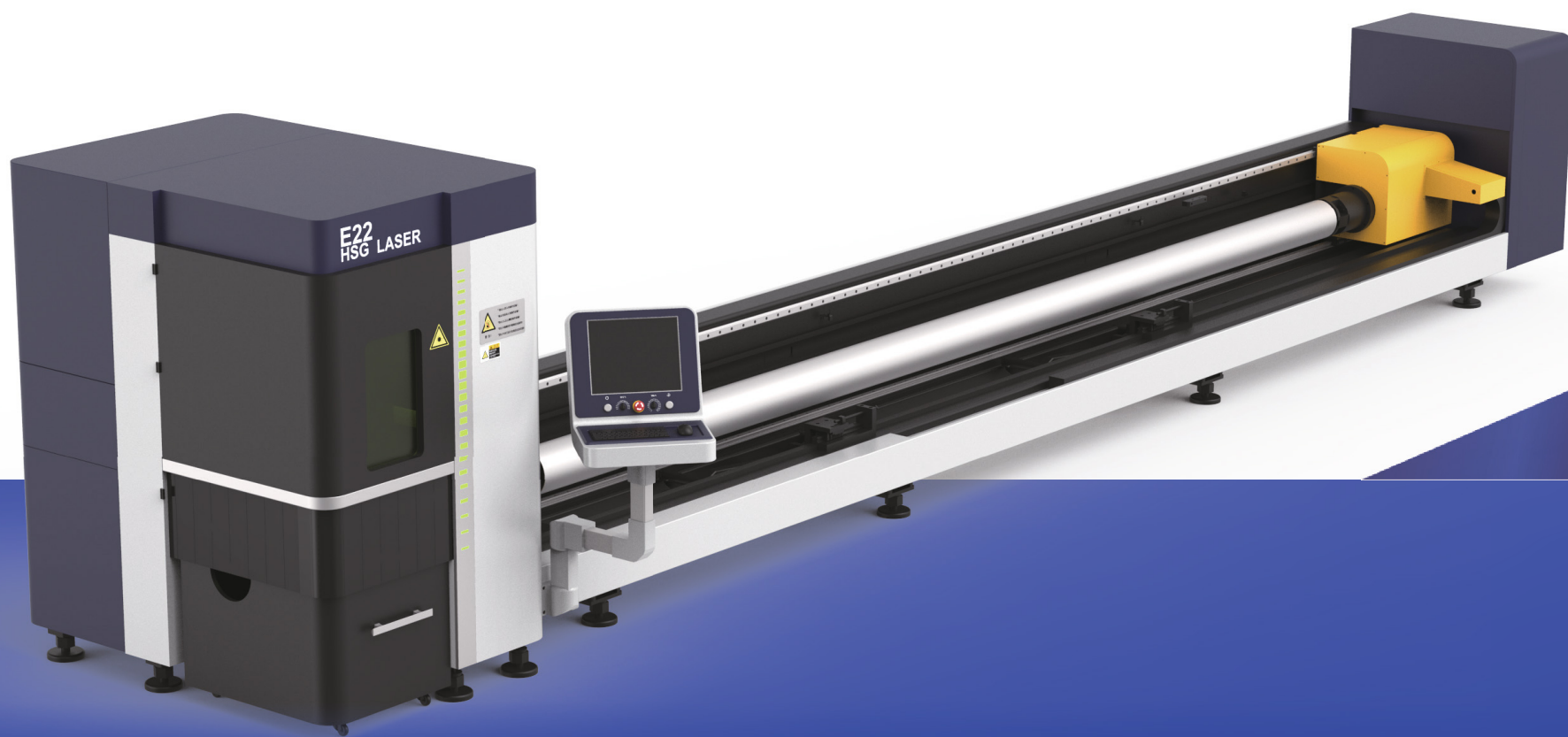

▲ 全自动

▲ 一体机床

▲ 激光切管

应用材料 / Applicable materials

管材

专业切割方管、圆管、矩形管、D型管和六边形管等各类型管材，方管口 20*20-150*150mm，圆管 Φ 20- Φ 210mm，管壁厚度 0.5-10mm 碳钢管，0.5-10mm 不锈钢管。（厚度以及材料与激光器有关）

TUBES

Professionally cutting square tubes, round tubes, rectangle tubes, D-shaped tubes and hexagon tubes etc. Cutting capacity- square tubes: 20*20-150*150mm, round tubes: 20-210mm, thickness 0.5-10mm carbon steel tubes, 0.5-10mm stainless steel tubes.

① 行业首创 L 型机械结构一体化床身，性能稳定，设备运行平稳，提高了传动件的使用寿命、保证机床的运动精度；

② 该机型采用交流伺服电机驱动系统，机床运动机构采用齿轮齿条传动，直线导轨导向，保证设备的高速度、高精度、高可靠性；

③ 全自动、全行程气动卡盘，瞬间即可自动定心夹紧工件，无需二次调节夹具，同时可通过调节气压大小，保证夹持力稳定可靠；

④ 巧妙的支撑设计能够保证切割圆管、方管、矩形管、异性管等都能很好的支撑管材，同时可以有效减小管材对夹具的磨损。

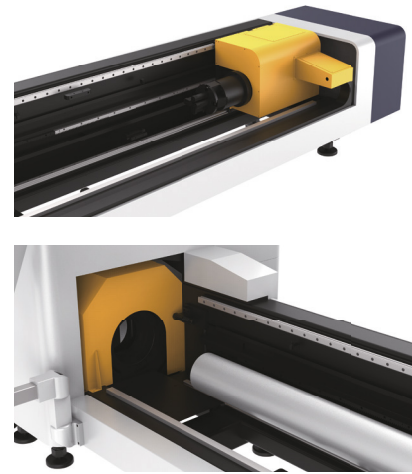

性能指标参数 / Performance Index

激光波长	Laser Wavelength	1070-1080mm
激光器功率	Laser Power	1000W-3000W
最大运行速度	Max. Moving Speed	60m/min
最大加速度	Max. Acc. Speed	0.5G
定位精度	Positioning Accuracy	\pm 0.05mm/m
重复定位精度	Reposition Accuracy	\pm 0.05mm
整机重量	Whole Machine Weight	5000Kg
外观尺寸	Machine Dimensions	9500*2700*2400mm



THREE-DIMENSIONAL LASER CUTTING MACHINE

三维激光切割机

MASTER THE TECHNOLOGY
CREATE THE FUTURE
掌握科技·开创未来

HS-R30A

HS-R20

HS-R30A

▶ 三维机器人光纤激光切割机

3D ROBOT FIBER LASER CUTTING MACHINE



▲ 3D 机器人

▲ 激光切割



- ① 光纤激光机器人切割系统能够自由、灵活的实现各种复杂三维曲线加工轨迹；
- ② 采用柔韧性好、能够远距离传输激光光纤作为传输介质，不会对机器人的运动路径产生限制作用；
- ③ 集中式操作、移动速度快、加工精度高，稳定提高切割质量；
- ④ 改善工人劳动强度，降低对工人操作技术的要求和人工成本。

- ① Fiber cutting robot cuts various complicated three dimensional curves freely and flexibly;
- ② Adopt flexible fiber laser source that can transfer in a far distance as the transferring media, it wont limit the working path of the robot;
- ③ Concentrated operation, fast moving and precise processing enhance the cutting quality stably;
- ④ Reduce the labor intensity and avoid high requirement on the worker technique and labor cost.

性能指标参数 / Performance Index

最大负载	Max. Loading Weight	30kg
额定负载	Rated Loading Weight	16kg
臂展	Arm Length	2000mm
关节数	Joint Quantity	6
可重复精度	Reposition Accuracy	±0.05mm

HS-R20A

▶ 三维机器人光纤激光切割机

3D ROBOT FIBER LASER CUTTING MACHINE

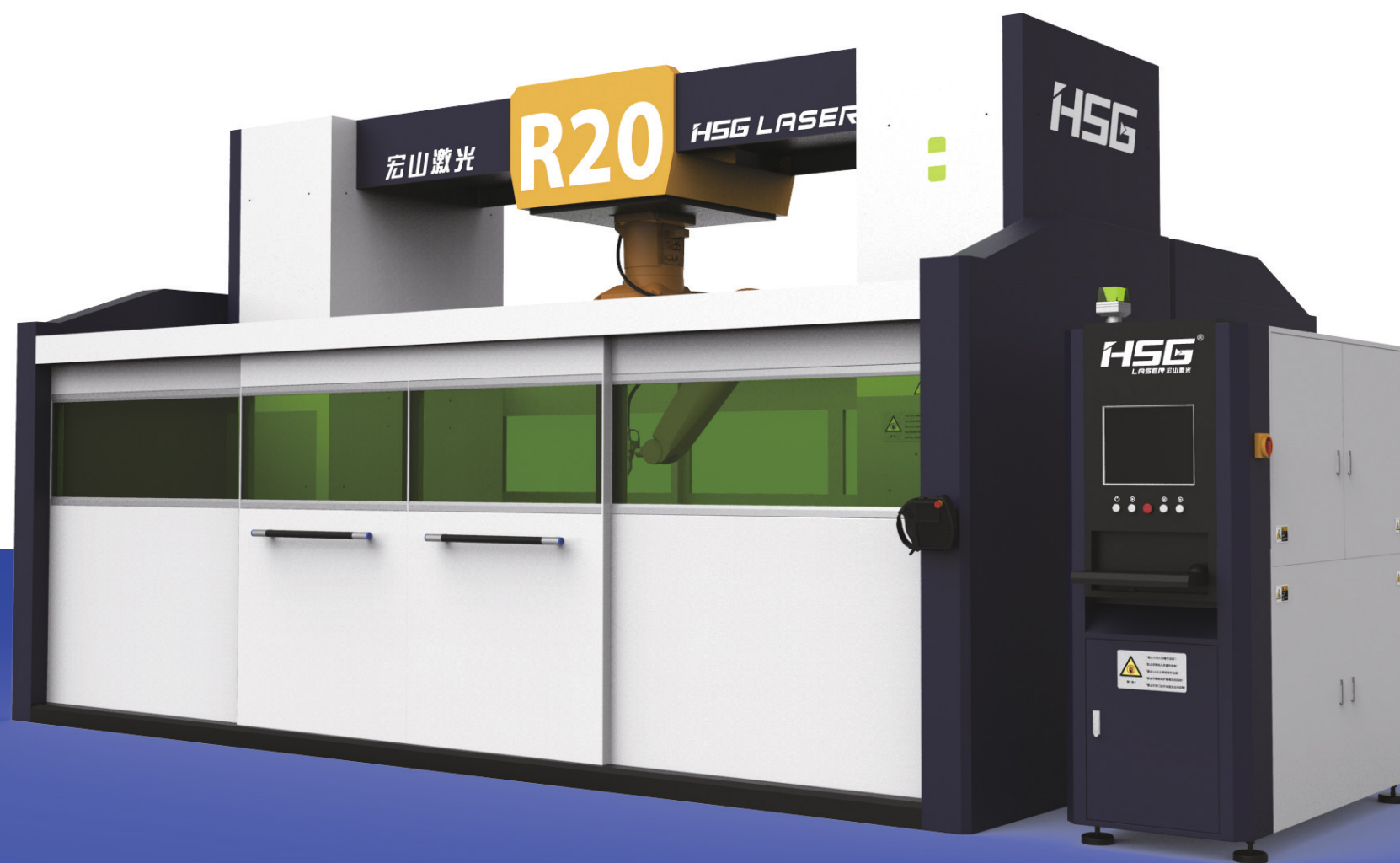

▲ 3D 机器人

▲ 激光切割



- ① 设备采用了单机械手臂置顶式结构，在规定的工作台范围内实现空间任意点的切割；
- ② 为了保证整机的高运动性及优异的动态平衡性，A1-A6 轴均采用瑞士原装伺服控制器、电机。整机空程速度达到 120m/min，属于三维激光切割设备；
- ③ 数控系统采用 LASMAN 机器人激光切割系统，整套系统集成度高、功能完善、稳定性强、技术领先。

- ① Single-arm top structure, the device could realize any point cutting within ordered range;
- ② A1-A6 axis use swiss-imported controller and motor to make sure high running and dynamic performance. The max. running speed reaches to 120m/min. It's 3D Laser Cutting Equipment;
- ③ CNC controlling is LASMAN robot laser cutting system. The whole system is high intergration, perfect function, high stability with leading technology.

性能指标参数 / Performance Index

最大负载	Max. Loading Weight	28kg
额定负载	Rated Loading Weight	14kg
有效切割范围	Arm Length	2010mm
轴数	Axis Quantity	6
可重复精度	Reposition Accuracy	±0.03mm
工作最小孔直径	Min. Hole Diameter	3mm



FIBER LASER WELDING MACHINE

光纤激光焊接机



PERFECT QUALITY
WELDING SOLUTION
完美品质·焊接栋梁

HS-W20A

HS-W30

HS-W20A

▶ 三维多工位激光焊接机

3D LASER WELDING MACHINE WITH
MULTIPLE PLATFORMS



▲ 3D 多工位

▲ 激光焊接

应用 / Applicable

此系列设备主要由激光发生器、水冷机、扫描振镜激光焊接头、柔性工作台、六轴机械手和操作台组成，广泛应用于电池、手机壳体、太阳能、汽车零部件等产品的生产。

This series of equipment, mainly composed of fiber laser resonator, water chiller, scanning galvanometer laser welding head, flexible working platform, 6-axis robot arm and operation platform, it's widely used for the production of battery, mobile phone cover, solar energy, automobile parts etc.

① 连续波输出，焊缝致密性好，强度高

Continuous wave output, excellent welding seam compactness with high intensity.

② 柔性工作平台，可根据客户要求设计夹具组合

The fixture/clamp could be designed according to customers' needs to be combined with the flexible working platform.

③ 激光热量集中，焊接速度快，热变形小

Concentrated laser heat, rapid welding speed and small thermal deformation;

④ 设备电光转化效率高，无需额外焊材，成本低

The equipment has high electro-optic conversion efficiency requiring no additional welding material. And the cost is low;

⑤ 核心部件基本免维护，使用成本低

Basically, the core components are maintenance-free thus the running costs is low.

⑥ 可设计多工位协同工作，轮流上下料，提高生产效率

Multi-station cooperative work can be designed to realize loading and unloading alternately thus to enhance productivity;

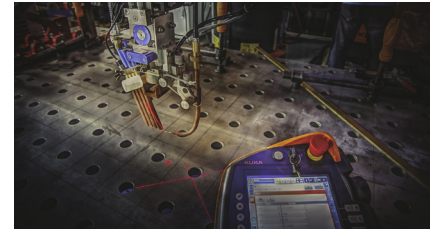

HS-W30

▶ 高功率焊缝跟踪填丝焊

HIGH-POWER SEAM-TRACKING AND
WIRE-FEEDING LASER WELDING MACHINE



▲ 高功率

▲ 填丝焊缝

应用 / Applicable

此系列设备主要由激光发生器、水冷机、激光焊接头、柔性工作台、六轴机械手和操作台组成，广泛应用于电池、手机壳体、太阳能、汽车零部件等产品的生产。

This series of equipment, mainly composed of fiber laser resonator, water chiller, laser welding head, flexible working platform, 6-axis robot arm and operation platform, it's widely used for the production of battery, mobile phone cover, solar energy, automobile parts etc.

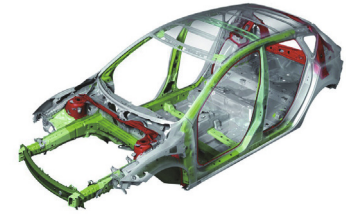
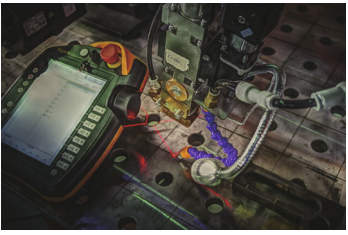

- ① 配备焊缝跟踪系统，根据焊缝位置精确校正 3D 轨迹，通过测量待焊缝的特征，确保能够及时优化且实时调整焊接参数，采用高精度冷丝填充系统应对更宽的间隙

Equipped with gap-tracking system, precisely adjust 3D path according to the position of the joint. Through detecting the features of the to-weld joint, ensuring optimization and real-time adjustment of the welding parameters, and adopting high-precision cold wire filling system to cater to wider gaps;

- ② 精确测量工件的变化，在激光切割板和剪切板上实时调整工具位置。专利技术补偿机器人或专机的可重复误差，通过减少示教点数，极大地减少系统设置与调试时间

Precisely measuring the change of the objects, to adjust the position of the workpiece on the laser cutting platform and clipboard. Patented technology make compensation for repeatable error of robot or special machine, through reducing the teaching point, greatly reducing the time of system setting and commissioning.

- ③ 设备支持离线编程，充分利用计算机的功能，减少手工示教机器人程序所用的时间，极大提高生产效率和灵活性

The equipment supports off-line programming, with full application of the computer functions, reducing the time of writing robot program and greatly enhancing production efficiency and flexibility;

- ④ 闭环伺服控制的高速执行器，根据接头位置精确校正 3D 轨迹

Closed-loop servo control high-speed actuator, precisely adjust 3D path according to the position of the joint;

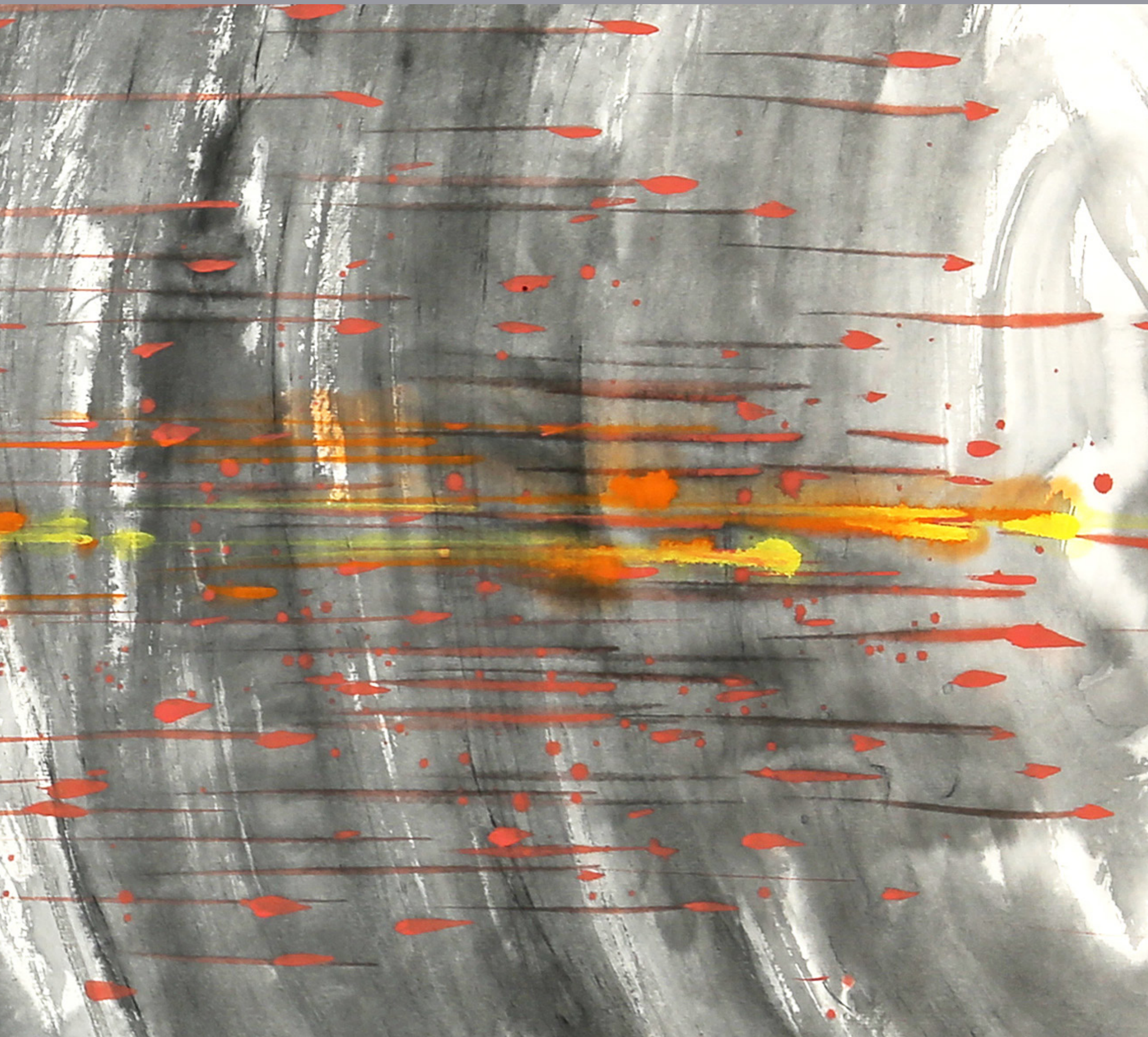

AUTOMATED PRODUCTION LINE

切管自动化生产线

INTELLIGENT MANUFACTURING
CHANGES THE FUTURE

智造改变未来

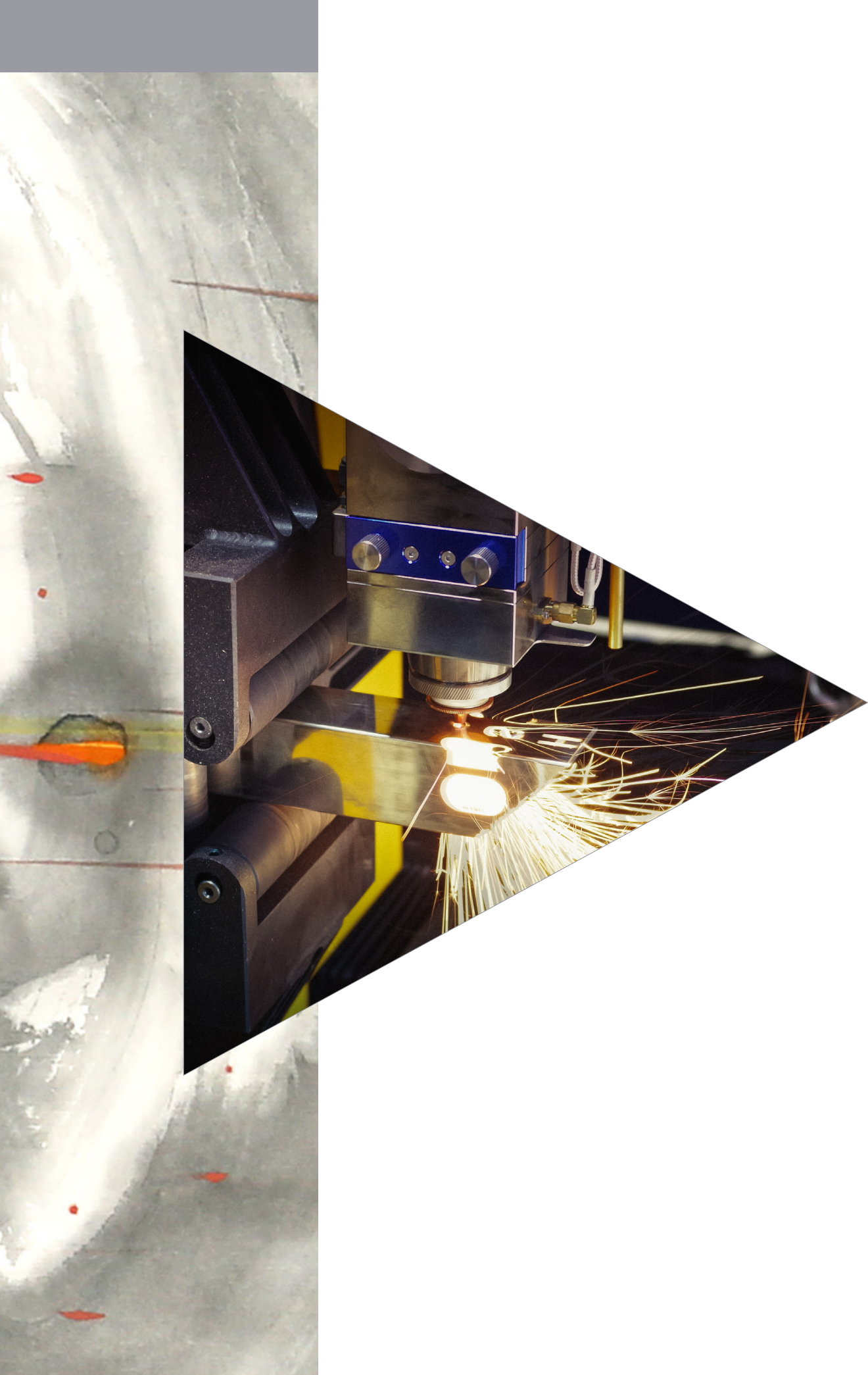

▶ 五轴联动激光管材智能生产线

5 AXIS TUBE LASER CUTTING
INTELLIGENT PRODUCTION LINE



▲ 五轴联动

▲ 智能生产线

国内首台五轴联动 激光管材智能生产线

智能产线，可提供定制化解决方案



▶ 汽车座椅弯管产线

AUTOMOBILE SEAT ELBOW
TUBE PRODUCTION LINE

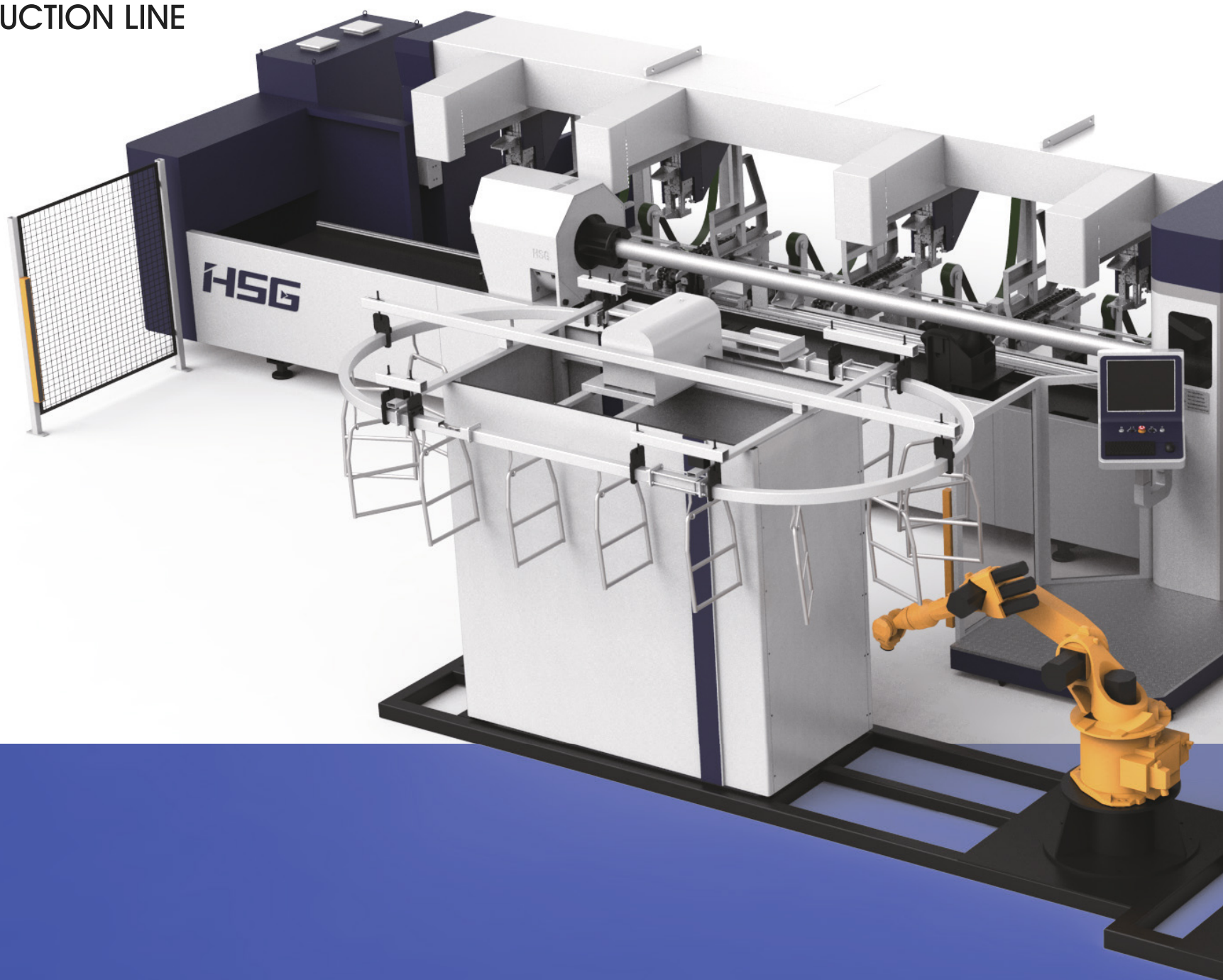

▲ 全自动卡盘

▲ 弯管生产线

全自动定心动力卡盘

保障较长管材被夹
紧时的平整度和送料精准度

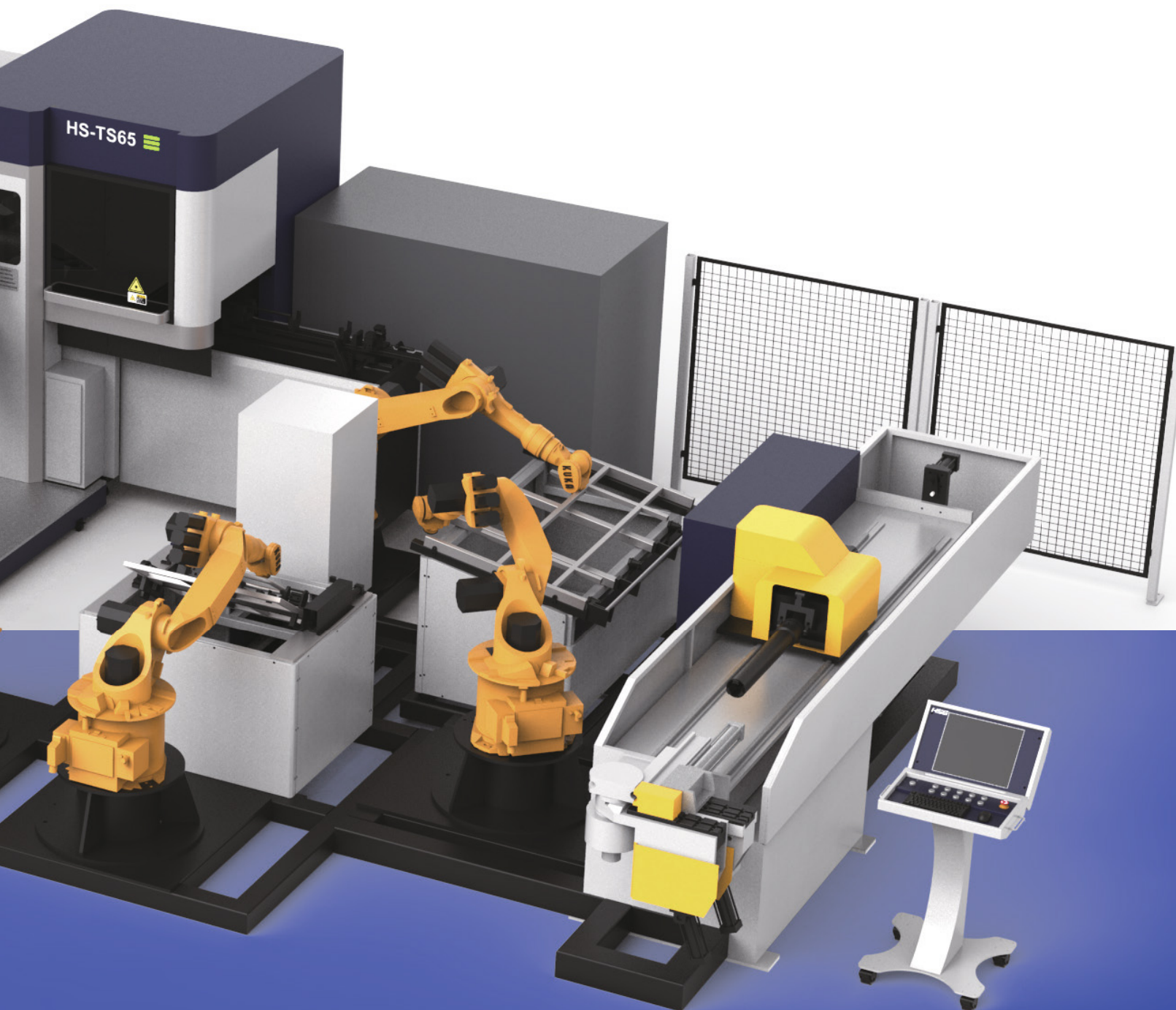

▶ 超简易料库

SHEET METAL SIMPLE
STACKING WAREHOUSE



▲ 全自动机器

▲ 易料库

全自动上下料机器人

自动板材厚度测量
板材分离功能和双层板材检测功能

